



PRESSURE SWITCHES
PRESSURE DIFFERENCE SWITCHES
VACUUM SWITCHES
From 1.5 mbar to 600 bar

145.0

(5.71)

126.0

(4.96)

Cable Entry
1/2" NPT(F)
(Options Avail.)

FR Flameproof Switch

INSTALLATION AND OPERATING INSTRUCTIONS

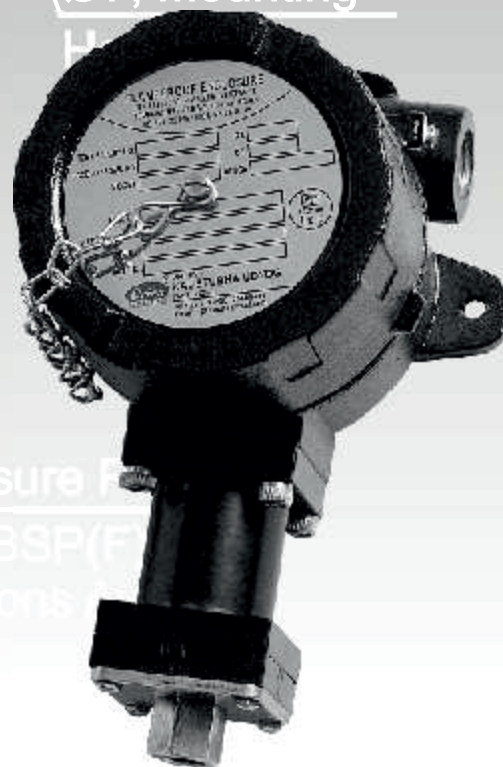

Ø7, Mounting

Pressure P
1/4" BSP(F)
(Options)



Certificate No.: **FM 72815**

Kaustubha Udyog AN ISO9001:2000 COMPANY

S. No. 36/1/1, Sinhgad Road, Vadgaon Khurd,
Near Lokmat Press, Pune 411 041 INDIA
Tel.: +91-(0) 20-24393577 / 24393877
Telefax : +91-(0) 20-25460486 / 24393577
Email : ku.pressure@gmail.com

Website : <http://www.orion-instruments.io>

Installation and Operating Instructions for Flameproof Switch

CONSTRUCTION:

A flameproof pressure switch consists of a flameproof body and cover (normally of die cast aluminium / Grey CI / SS), a junction cylinder (aluminium) and the pressure capsule. The pressure in the pressure capsule is converted to a force which is balanced by a spring in the junction cylinder. When the force generated by pressure exceeds / falls above / below the spring force, a microswitch housed in the flameproof enclosure is actuated by a transfer rod.

A separate terminal strip with screwed ends is provided for easy and safe wiring. The cables need to be passed through a conduit entry which is 1/2" NPT/ 3/4" NPT or M20 X 1.5, as selected. The other cable / conduit entry, if not used, needs to be suitably plugged.

INSTALLATION

WARNING

Your attention is drawn to the electrical potential that will be present, if the main cover is removed while the switch is connected to a live supply. The electrical supply **MUST BE ISOLATED** prior to removal of the cover.

Similarly, on pressurized process systems, prior to removal of an instrument, it should be isolated from the pressurized medium or the system pressure should be relieved.

The unit must be specified, installed and operated by competent personnel, & its use be limited to within the published specifications. (all hazardous area models must be installed in accordance with BS EN 50079-14)

Unauthorized modifications repair, or operation outside the specified limits may invalidate the warranty. Servicing should only be carried out by qualified personnel.

On pressure devices, pulsation or surges be anticipated, then a suitable pressure snubber should be fitted.

INTRINSICALLY SAFE APPLICATIONS

- 1) The pressure switch is a simple apparatus as it does not generate or store energy. Because of low voltages and currents it is recommended to use gold contacts and/or hermetically sealed contacts.
- 2) Pressure switches can be used in intrinsically safe systems provided the power source is certified IS.

FAILURE HAZARD

Pressure switches element/ primary seal failure.

In the event of the above, the process medium will be prevented from entering and pressurizing the main body by relieving it to atmosphere via vent holes.

The process medium temperature should not be allowed to exceed that stated in the product data & under the "OPERATING TEMPERATURES" section in this document. If process temperatures in excess of those stated are possible, then the switch should be remote mounted via a length of tubing or pipe.

PROCESS CONNECTIONS

Pressure & Differential Pressure Switches

Various process entries are available, & the installations will vary dependant on exact type. It is recommended that PTFE tape is used on tapered fittings & the use of the correct size of bonded seal on parallel fittings.

In some cases, flanged end connections too could be provided.

MATERIALS

The materials used in this switch are as follows:-

The Main casing - Aluminum Grade- LM6 or Grey Cast Iron / SS316 Grade Stainless Steel (on demand)

The Cover - Aluminum Grade- LM6 or Grey Cast Iron / SS316 Grade Stainless Steel (on demand)

The wetted parts - SS316 or EPDM/PTFE

Internal switch mechanism - SS

External fasteners - SS

Internal fasteners & springs - S.S / Spring steel

MOUNTING

The high pressure range pressure switches can be mounted in any direction. However, for low range pressure switches, it is advised to mount them in such a way that the diaphragm is vertical.

- 1) for high range pressure switches,
 - a) pressure switches can be mounted directly in case the mounting is rigid.
 - b) For panel mounting, use M6 bolts of appropriate length through the mounting holes. If the equipment is subject to vibration, please use the rubber washer / pads between the panel and the switch.
- 2) for low pressure ranges :
 - a) Pressure switches can be mounted directly in case the mounting is rigid
 - b) For pipe mounting, use a pipe mounting bracket that can be provided along with the pressure switch, to clamp the switch on to the pipe.
- 3) connect the pressure tubing to the pressure port. The pressure port size is generally 1/4" BSP/NPT and 1/8" BSP/NPT (FEMALE), unless specifically ordered otherwise. Other sizes can be obtained via adaptors.

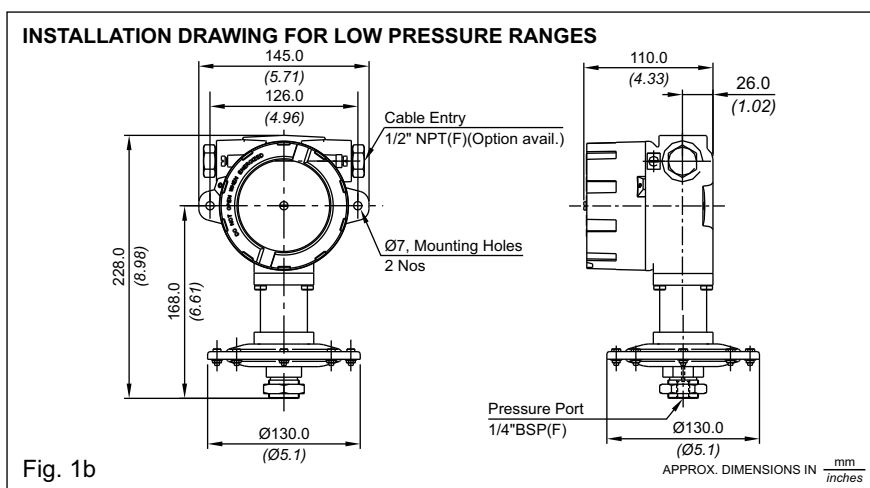
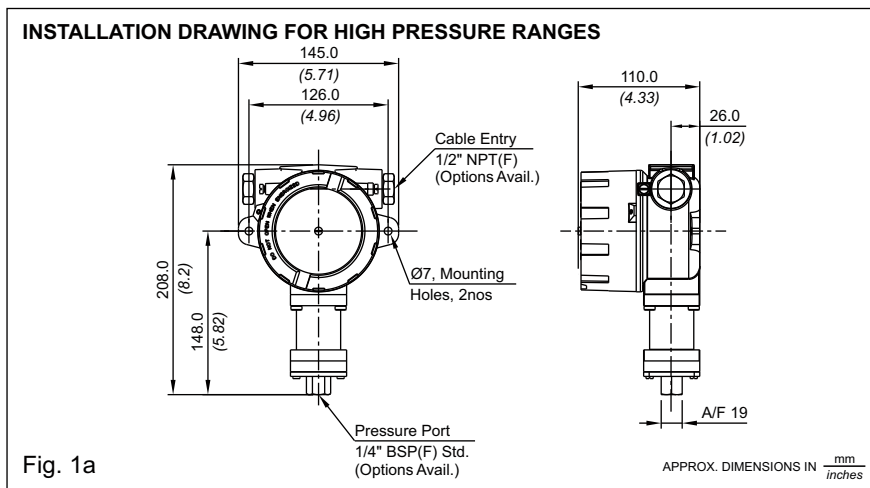

INSTALLATION DRAWING FOR HIGH RANGE PRESSURE DIFFERENCE SWITCHES

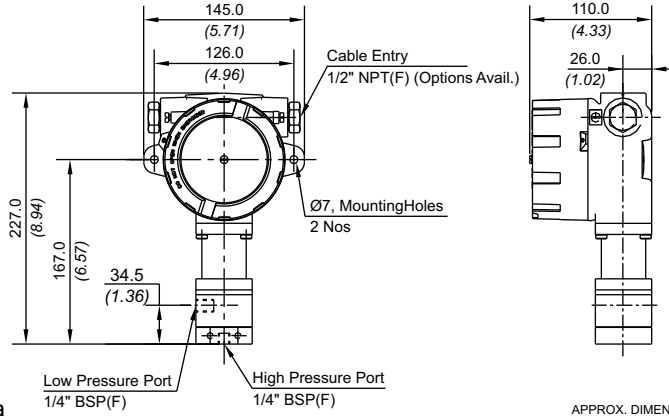

Fig. 2a

APPROX. DIMENSIONS IN $\frac{mm}{inches}$

INSTALLATION DRAWING FOR LOW RANGE PRESSURE DIFFERENCE SWITCHES

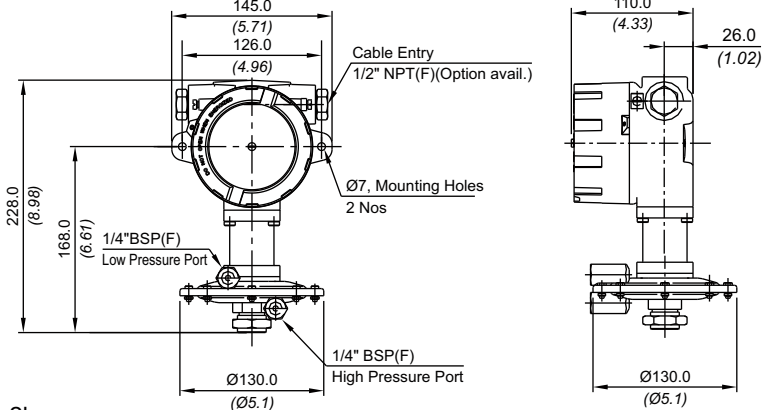

Fig. 2b

APPROX. DIMENSIONS IN $\frac{mm}{inches}$

INSTALLATION DRAWING FOR VACUUM SWITCHES

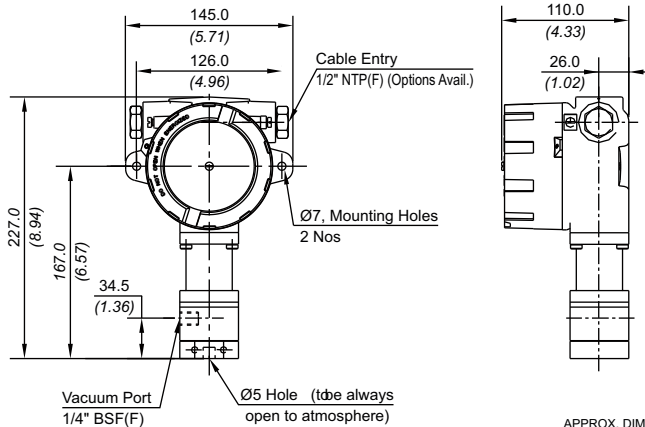

Fig. 2c

APPROX. DIMENSIONS IN $\frac{mm}{inches}$

INSTALLATION DRAWING FOR HYDRAULIC RANGES

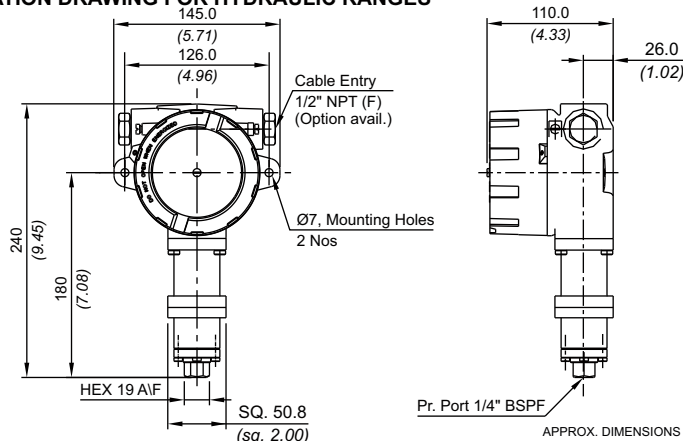

Fig. 2d

APPROX. DIMENSIONS IN $\frac{mm}{inches}$

ELECTRICAL CONNECTIONS:

Pressure switches will generally have only one SPDT microswitch.

Pressure switches with 2 SPDT microswitches can also be provided on demand.

All models are normally supplied with a straight M20 conduit entry provided on either side of the switch and either one can be plugged, if not in use. These conduit connections can either be fitted with either a suitable gland or directly with conduit to suit the installation.

Access to the terminal is via a removable top cover. The electrical supply must be isolated prior to this activity. Switch connections details are provided on the cover (name plate). This should be referred to when connecting it to the terminal strip as NO/NC. Terminal numbers vary depending on whether switch setting is falling or rising.

Terminals are suitable for cables, single or multi strand, up to 2.5 sq mm. When 2 SPDT microswitches are fitted, they are mechanically linked to give a DPDT switching action.

Reset of the switches could be up to 3% apart due to the inherent differential of microswitches. For specific wiring, refer the figure.

WIRING:

a) Your attention is drawn to the electrical potential that will be present, if the main cover is removed while the switch is connected to a live supply. The electrical supply must be isolated prior to removal of the cover.

b) Remove the cover. Refer fig 3

c) Pass the cable through the cable gland and connect the wiring to the terminal strip as per your wiring diagram.

The color code is as per the details given below:

- Terminal 1 (Common) : Red
- Terminal 2 (Normally closed) : Black
- Terminal 3 (Normally open) : Yellow

OPERATING TEMPERATURES:

The operating condition temperature restrictions for the Flameproof switch FR are as follows:

Ambient : -55° C to +60° C

SET POINT ADJUSTMENT:

FOR FLAMEPROOF MODELS Refer figure 3

1. ISOLATE SUPPLY. Remove the cover.
2. i) FLAMEPROOF UNCALIBRATED Models : Turn the setscrew to the extreme negative end.
ii) FLAMEPROOF CALIBRATED Models : Adjust the desired set point on the scale.
3. Apply the desired pressure to the pressure switch.
4. i) FLAMEPROOF UNCALIBRATED Models : Increase the pressure setting by turning the setscrew till contacts changeover.
ii) FLAMEPROOF CALIBRATED Models : Proceed to Step 5.
5. Some minor adjustment will be required to achieve the exact point, which can be checked with the help of a proper pressure measurement device.
6. Replace the cover.

Tip :The pressure switches are factory set at half the set point range (unless otherwise specified in a Purchase Order). Step 2 can be omitted if the desired set point is more than the factory setting, for FLAMEPROOF uncalibrated models.

SETTING AND CALIBRATION

Prior to despatch, switches are checked to ensure the adjustment range is achieved and when requested preset at a specified value against a calibrated test instrument. A switch has tamperproof adjustment accessed by removal of the main cover. Adjustment to the set point is carried out by rotating the nut/shaft to the left to increase or to the right for decreasing the load respectively.

ROUTINE MAINTANENCE:

Routine inspection of the installation should take place at regular intervals. It is recommended that the switch is checked and operated every 5 months. Electrical connections and covers should be checked periodically for tightness. It is recommended that the 'O' rings and diaphragms be renewed every 3-5 years, and microswitch assemblies every 5-10 years dependant upon equipment usage.

TROUBLE SHOOTING TIPS

WARNING: Isolate the switch electrically and disconnect from

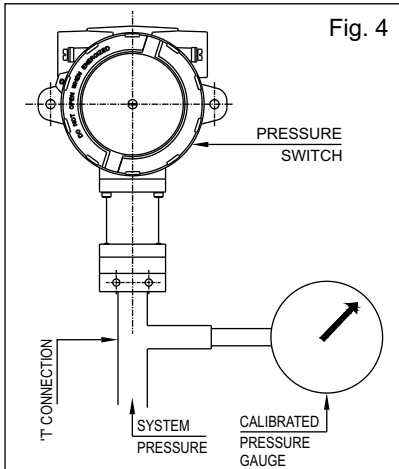

pressure source before carrying out trouble shooting, in a safe area. Generally no problems are observed if the pressure switch selection, wiring and the set point is proper. For a pressure switch selection procedure, please consult our sales office.

For properly selected pressure switches, if following symptoms are observed, the likely causes and remedies are as stated below.

SYMPTOM 1: SWITCH DOES NOT OPERATE

- 1) Wiring may not be correct, Check electrical connections to the pressure switch, if they are as per the wiring diagram.
- 2) Pressure does not reach the pressure port.
 - a) Check if the entry to the pressure capsule is not blocked by frozen process or scales or impurities in the process.

Fig. 3

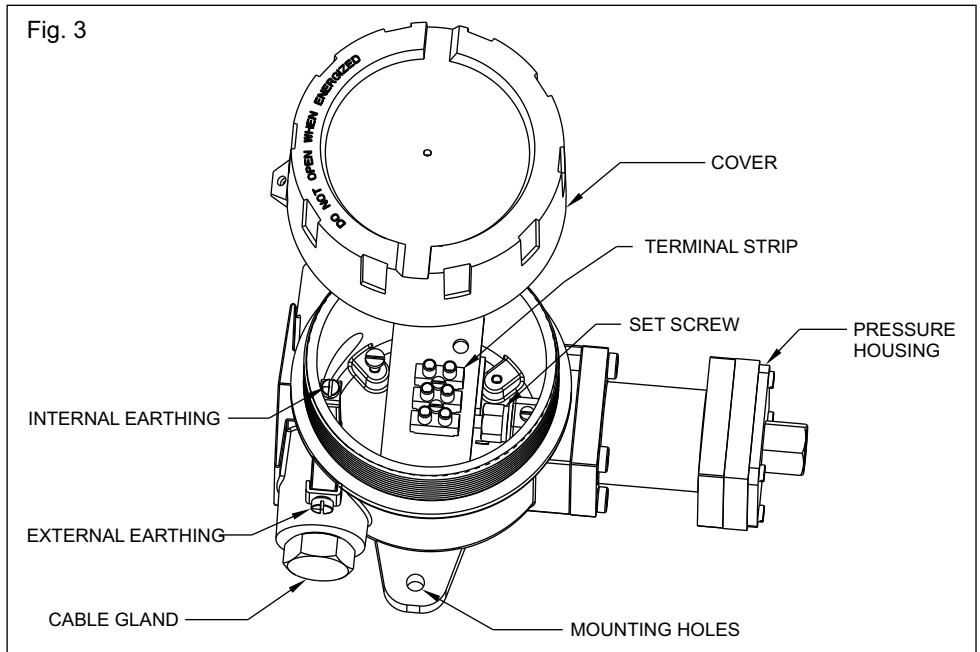

- 2) Pressure does not reach the pressure port.
 - a) Check if the entry to the pressure capsule is not blocked by frozen process or scales or impurities in the process.
 - i) If this is the case, try freeing the blocked path by a blunt tool in case of scales and impurities.
 - ii) For frozen process, it is advisable to use chemical seals.

DO NOT OPEN THE PRESSURE CAPSULE IN ANY EVENT

If the cause is none of the above-mentioned probabilities, proceed as per the following steps.

- b) Check the system pressure & set point of pressure switch. For use of pressure switch for falling set points, system pressure has to be greater than the cut out point. For use of pressure switch for rising set points, the system pressure may not be reaching the cutout point.
 - i) Use 'T' connection & connect calibrated pressure gauge to the 'T' connection as shown in the figure 4.
 - ii) Adjust the set points such that the system pressure is greater than the cut out points of the pressure switch.
 - iii) If the switch still does not operate, remove the pressure switch physically from the system. There should be continuity between terminals 1 & 2. If no continuity is observed the pressure switch should be returned to the factory.

SYMPTOM 2: LEAKAGE

In case leakage is observed, the pressure switch has to be returned to the factory without opening the pressure capsule. Check for the following likely causes and use a new switch taking proper precautions.

- a) System pressure is greater than working pressure: Use an over range protector or a switch with appropriate maximum working pressure.
- b) Incompatible wetted parts: The working medium may not be compatible with wetted parts, which damages the sealing of the process from working parts. Use a chemical seal for the pressure switch or use proper compatible wetted parts.
- c) Excessive process temperature: Process temperature may exceed maximum allowable temperature.

SPARES AND PART REPLACEMENT

We strongly recommend for spares and part replacement, kindly contact Kaustubha Udyog, Pune, India. ■